









Widened and thickened seat cushion



NE125 engine, Superior performance at low and medium speeds



Off road tire



Large diameter front drum ( $\Phi 130$ ), improve braking performance



Handlebar safety bumper



Headlight bumper



## Standard configuration

- NE125 engine, Electric / kick start, international gear shift (4 speed)-spoke wheel-half chain guard-Rectangular tube fork-rear carrier-Integral seat-black mirror-off road tyre-Front drum brake ( $\Phi 130$ ) . rear drum-Plunger carburetor-Roundness headlight-oval turn lights-single mechanical speedometer-gel battery-single horn

## Optional

- hand saver
- black front guard
- large padel with protective net



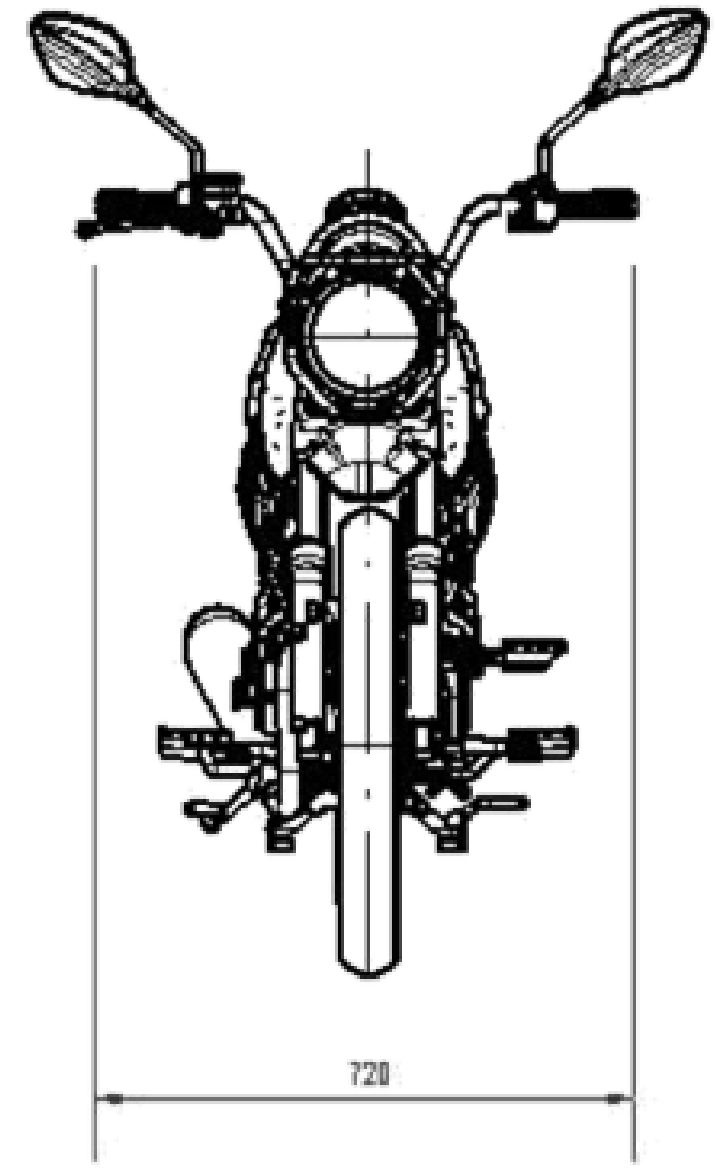
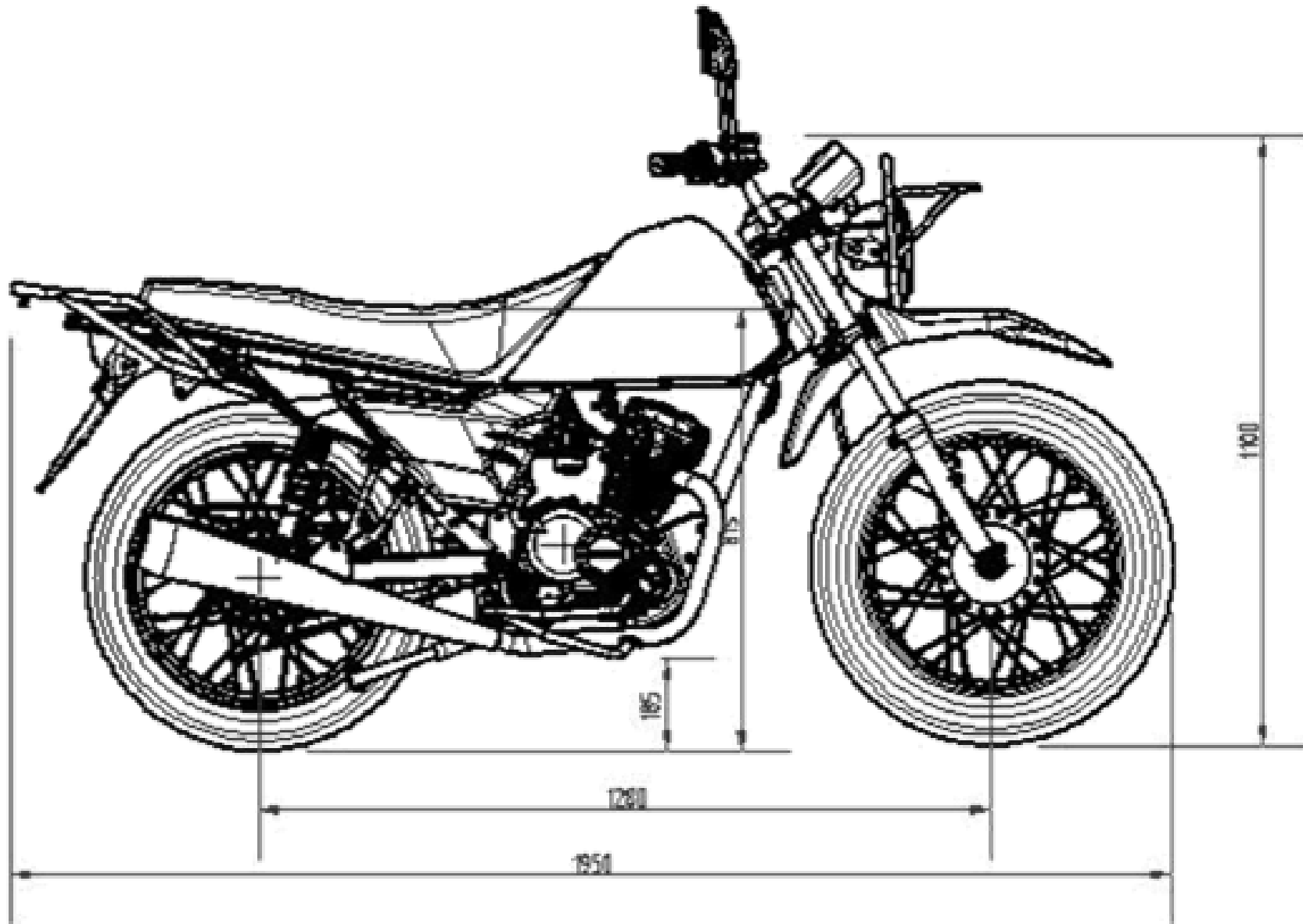



<b>Model</b>	NE125, single cylinder, 4 stroke, wind cooling, Vertical	<b>Dimension(L × W × H)mm</b>	1950×720 ×1100
<b>Displacement ml</b>	124.8	<b>wheel base mm</b>	1280
<b>Bore x Stroke mm*mm</b>	52.4×57.9	<b>Seat height mm</b>	815
<b>Compression ratio</b>	9.0:1	<b>Min. ground clearance mm</b>	185
<b>Max. power kw/ (r/min)</b>	6.2/7000	<b>Net weight kg</b>	105
<b>Max. torque N.m/ (r/min)</b>	9.5/5500	<b>Fuel capacity L</b>	10
<b>Gear type</b>	4 speed international gear shift 1-0-2-3-4	<b>Front tyer</b>	2.75 – 17
<b>Starting method</b>	electrical , kick	<b>Rear tyer</b>	3.00-17
<b>Ignition method</b>	CDI	<b>Brake (front/rear)</b>	drumΦ 130/drumΦ 110
<b>Oil Qty.(L)</b>	1	<b>Max. speed km/h</b>	90
<b>Clutch type</b>	Automatic wet multi-piece	<b>Battery</b>	12V 6.5AH
<b>Lubrication method</b>	Pressure splash	<b>Wheel type(Alloy/spoke)</b>	spoke
<b>transfer method</b>	Chain	<b>Front suspension</b>	Spring and damper



Oil injection piston cooling system

Roller rocker technology

Cylinder offset technology

Camshaft and rocker integrated cylinder head

Multi-channel wind cooling design

**Thank You**

