







YZL-150TT

YZL-200TT









High-quality led Taillight of diamond-shaped, sharp and kinetic. It provides more glaring illumination, safer driving and longer usage than normal taillights.



A new high-quality LED turning light not only gives more glaring illumination but also assures safer driving and longer usage.



New hand protector, enhance driving experience.



Half-basket Frame structure provides higher strength and better resistance to vibration. Very good protection for the engine when ride on the rough roads.



Full functional meter. Fashion sport style, clear indicator, and compact appearance.



New alien style headlamp, beautiful appearance, wider and brighter illumination and better for night riding.



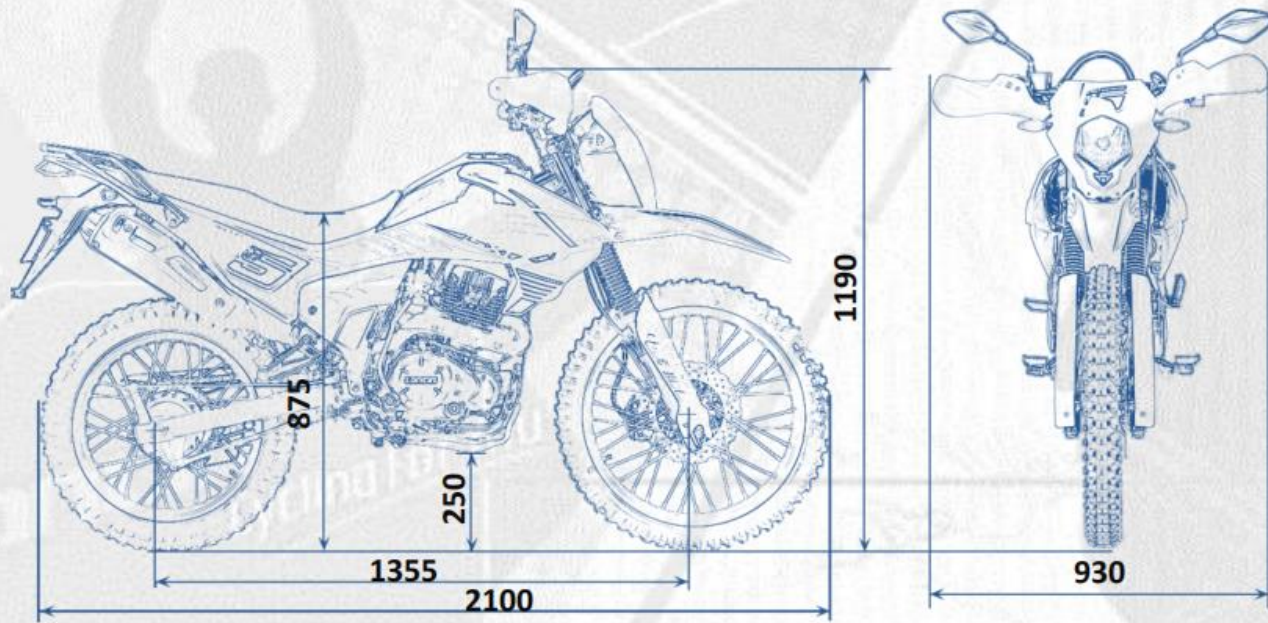

**Overall size (L × W × H) mm** 2100 × 930 × 1190

**Wheel base** 1355 mm

**Seat height** 875 mm

**Ground clearance** 250 mm

**Net weight** 127 / 134 kg

**Brake type (Fr./Rr.)** Disc / Drum

**Front tyre size** 80/100-21

**Rear tyre size** 120/80-18

**Fuel tank volume** 12 L

**Maximum load** 150 kg

**Maximum speed** 95 / 109 km/h

**Battery** 12V 7AH

<b>Engine type</b>	Single cylinder, 4-stroke, air-cooled
<b>Displacement (cc)</b>	149 / 205
<b>Bore × stroke (mm)</b>	62 × 49.5 / 63 × 62
<b>Compression ratio</b>	9.0:1
<b>Maximum power</b>	11.4 hp (8.5 kW) / 8000 rpm / 14.1 hp (10.5 kW) / 7500 rpm
<b>Maximum torque</b>	10.5 N . m / 6500 rpm / 14.2 N . m / 6500 rpm
<b>Starting method</b>	Electric / Kick
<b>Ignition system</b>	C.D.I
<b>Transmission system</b>	5-speed
<b>Final transmission</b>	Chain
<b>Idle speed</b>	1300 ± 100 rpm
<b>Engine oil volume</b>	1.1 L

## Configuration

CGP210 engine, E-start & Kick, Spoke wheel, Off-road tire, Fr. disk brake, Rr. Drum brake, Centre placed absorber, Special headlight, LED taillight, LED turn light, Alloy rear armrest, Anti-slip seat with good elasticity, Half chain case, USB charger, Hand protector, Emergency button.



**THANK YOU**

---